



Intelligent Battery Charging Programmer Software User Manual



Intelligent Battery Charging Programmer Software User Manual

1. Introduction	1
2. Prerequisites	1
2.1 System requirements	1
2.2 Hardware installation	1
2.3 Software installation	3
3. User Interface	3
3.1 Basic layout	3
3.2 CURVE PROFILE	4
3.3 SETTING	4
4. General Operation	6
4.1 Connection	6
4.2 Parameter programming/Reading	6
4.3 File saving/ loading	7
5. Troubleshooting	9
5.1 Connection error	9
5.2 File loading/saving error	10
5.3 Uploading/downloading ERROR	11
6. Notes	12



Intelligent Battery Charging Programmer Software User Manual

1. Introduction :

For MEAN WELL's intelligent battery chargers, Charging curve programmable suitable for models: ENC-120/240/360,NPB-450/750/1200/1700,DRS-240/480,HEP-1000,HEP-2300-55,RPB/RCB-1600,DBU/DBR-3200/NCP-3200.

What function is provided?

Charging parameter adjustment: Values of constant current (CC), constant voltage (CV), float voltage (FV) and taper current (TC) can be set and adjusted.

Battery temperature compensation: Various charging voltage compensation is provided for battery at different temperature conditions.

Timeout setting: Fully programmable timeout during stages enables to be set to shutdown the charger to prevent battery over-charge.

2. Prerequisites :

2.1 System requirements :

- Inter Pentium 4 1GHz
- 1 GB memory
- One free USB port
- At least 200 MB of free disk space
- Monitor with a resolution of 800 x 600 pixels
- Microsoft Window 7, Microsoft Window 10
- Microsoft .NET Framework 4.0 or higher

2.2 Hardware installation :

Prior to program a driver, the connection between driver and PC must be established first via the Programmer shown in the figure below. The following steps are suggested:

ENC series:

1. Remove the ENC from AC.
2. Connect Programmer and PC with the enclosed USB cable. LED (GREEN) of the Programmer is ON.
3. Connect the communication cable to CN31 of the ENC from the Programmer.

RPB/RCB \ DBR/DBU \ NCP series:

1. Remove the RPB/RCB \ DBR/DBU from AC.
2. Connect Programmer and PC with the enclosed USB cable. LED (GREEN) of the Programmer is ON.
3. Connect the communication cable to CN1 and CN500 of the RPB(DBU) from the Programmer; RCB(DBR) requires working with a RHP rack, link the cable to JK1 of the rack.
4. Apply AC to the charger.
5. LED of the Programmer will light in ORANGE once connection is established successfully.

Note : For the detail of ENC/RPB communication cable, please refer to SBP-001 specification.

HEP-1000 series/HEP-2300-55:

1. Remove the HEP from AC.
2. Connect Programmer and PC with the enclosed USB cable. LED (GREEN) of the Programmer is ON.
3. Connect the communication cable to CN71 of the HEP from the Programmer.
4. Apply AC to the charger.
5. LED of the Programmer will light in ORANGE once connection is established successfully.

NPB series:

1. Remove the NPB from AC.
2. Connect Programmer and PC with the enclosed USB cable. LED (GREEN) of the Programmer is ON.
3. Connect the communication cable to CN71 of the NPB from the Programmer.
4. Apply AC to the charger.
5. LED of the Programmer will light in ORANGE once connection is established successfully.

DRS series:

1. Remove the DRS from AC.
2. Connect Programmer and PC with the enclosed USB cable. LED (GREEN) of the Programmer is ON.
3. Connect the communication cable to CN71 of the DRS from the Programmer.
4. Apply AC to the charger.
5. LED of the Programmer will light in ORANGE once connection is established successfully.

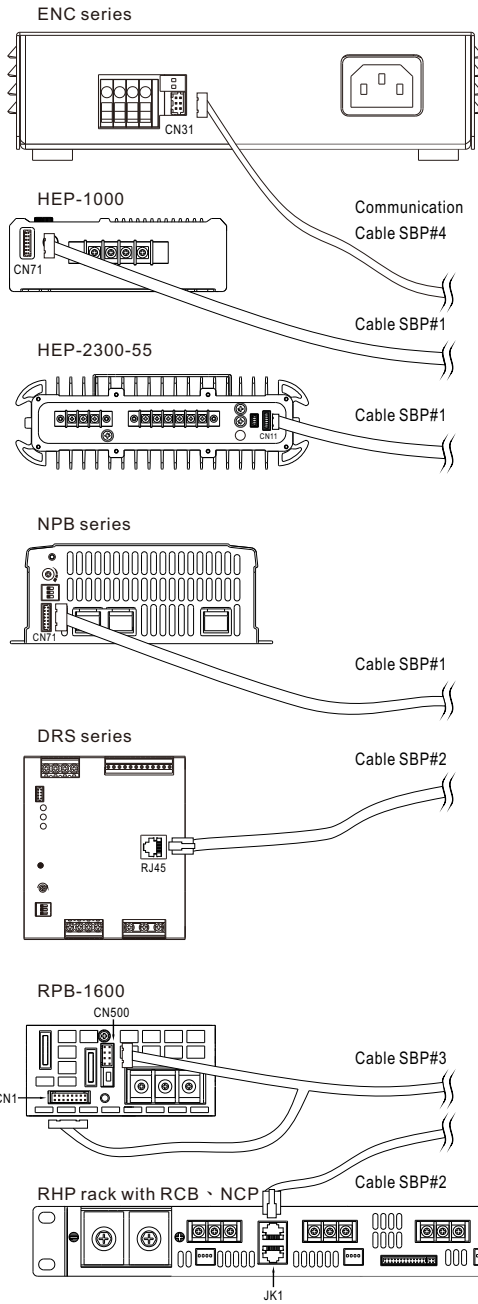

Communication
Cable SBP#4

Cable SBP#1

Cable SBP#1

Cable SBP#1

Cable SBP#2

Cable SBP#3

Cable SBP#2

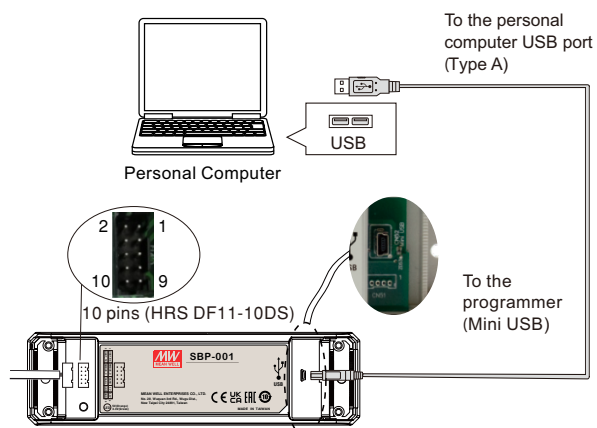

Charger VS Communication Cable

MW's charger		Communication Cable
Series name	Connector	
ENC-120/180/240/360	CN31	SBP#4
RCB-1600 DBR-3200/NCP-3200	JK1	SBP#2
RPB-1600/DBU-3200	CN1, CN500	SBP#3
HEP-1000 NPB-450/750/1200/1700	CN71	SBP#1
HEP-2300-55	CN11	SBP#1
DRS-240/480	RJ45	SBP#2

2.3 Software installation :

The Intelligent Battery Chargers Programmer Software is accessible via MEAN WELL and authorized distributors. After the download, it is packed and appears as ZIP file in the download folder.

The following steps are suggested:

1. Right-click at the ZIP file and select "Extract All...".
2. Choose a folder to save the software and click Extract.
3. If necessary, unplug the USB cable and install USB driver (PL2303_Proli_c_DriverInstaller_v1417.exe) and plug-in USB cable again.
4. If necessary, install the Framwork4 (dotNetFx40_Full_x86_x64.exe).
5. Double click the Smart Timer Dimming Program.exe.

3. User Interface :

3.1 Basic layout

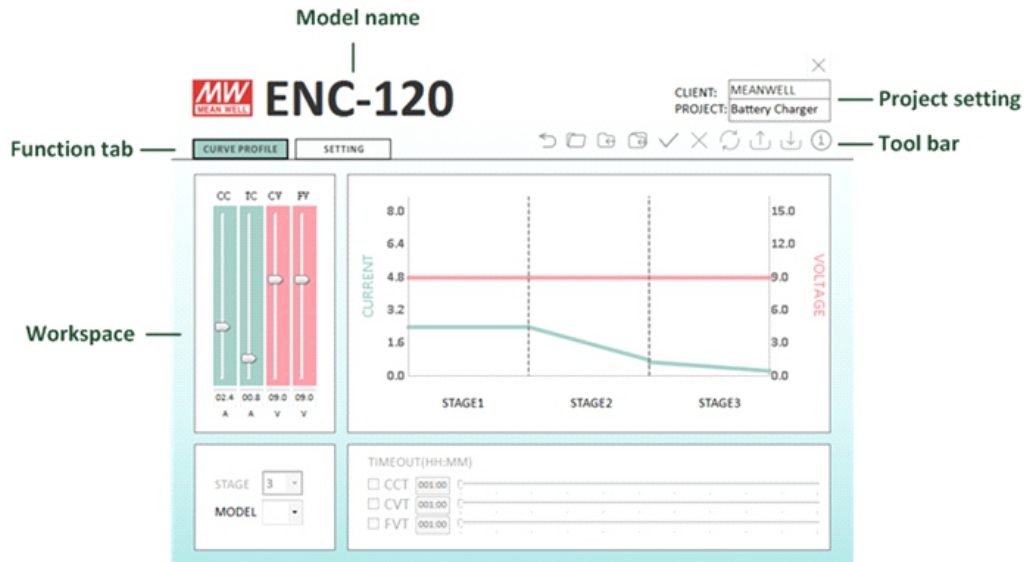

3.1.1 Tool bar



The toolbar provides instant access to the most important functions. The icons from left to right are:

Main Menu: Return to Main Menu

Open: Load an existing configuration

Save: Save the current configuration

Save as: Save the current configuration to a new file

Open Connection: Connect PC to Programmer via COM port

Close Connection: Disconnect PC from Programmer

Check Model: Reconnect the same model but different voltage type (e.g. ENC-120-12/24/48)

Upload to PC: Read the configuration from the charger

Download to Device: Send the current configuration to the charger

Information: Version of software and programmer

3.1.2 Function tab

The tabs are used to switch between functions by clicking.

3.2 CURVE PROFILE

This function allows users to set/program their own charge curves and preferred timeout setting.

CHARGING PARAMETERS: With these bars, it is able to adjust values of CC (Constant Current), TC (Taper Current), CV (Constant Voltage) and FV (Float Voltage) at any level. The curve on the right-hand side will change accordingly.

STAGE : 2 or 3 stages are selectable.

MODEL : Used to select different voltage type. If selected type does not match the charger, the software will enter offline mode.

TIMEOUT: Timeout function can be enabled to set a stop time for stop charging. The time format is HH : MM, range from 1:00 to 999:59. If STAGE is 2, then FVT cannot be set.

NOTE: 1. ENC series does not support STAGE and TIMEOUT functions.

- Owing to communication format of PMBus, there would be $\pm 0.1A$ tolerance on data transmission of CC and TC of RPB/RCB-1600. Take RPB-1600-12 as an example: set TC at 3.9A on the software, however, the actual TC of the charger would be 4.0A after clicking "Download to Device" to send the setting to the charger. TC would become 4.0A on the display when reading the setting back from the charger by "Upload to PC".

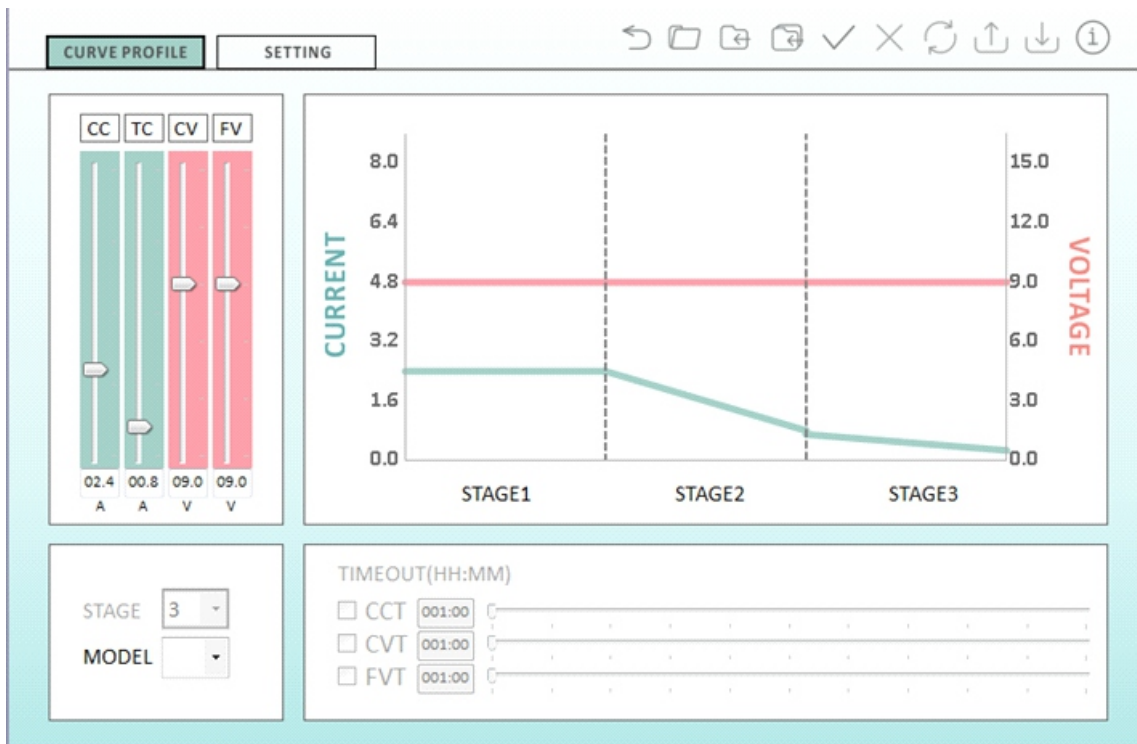

3.3 SETTING

There are temperature compensation, charging curve selection and address setting in the function.

TEMPERATURE COMPENSATION: There are 3 curves of battery temperature compensation available for selection.

CHARGING CURVE SELECTION: Some of the chargers support multi-charge curves (including RPB/RCB-1600, DBU/DBR/NCP-3200 and HEP-1000/HEP-2300-55 in charge mode), which allows you to choose a suitable curve for the battery. Of the functions, "Disable" supports (HEP-1000/DRS-240/480, NPB-450/750/1200 /1700) switching between power supply/charge modes, uncheck the box to enable charge mode or ticked to stay in power supply mode. "User's Definition" is used to customize a new curve when the embedded curves cannot satisfy you.

ADDRESS : Some of the chargers support multi-programming function that can program multi-units at the same time. Please designate the addresses and check corresponding address boxes on the software before programming.

(NOTE: Each charger must have a unique address, please do not connect units with the same addresses to the bus)

NOTE : ENC series does not support CHARGING CURVE SELECTION and ADDRESS functions.



ENC-120

CLIENT: MEANWELL
PROJECT: Battery Charger

CURVE PROFILE

SETTING



TEMPERATURE
COMPENSATION

- Disable
- 3mV/°C/Cell
- 4mV/°C/Cell
- 5mV/°C/Cell



ADDRESS

- Address #0
- Address #1
- Address #2
- Address #3
- Address #4
- Address #5
- Address #6
- Address #7
- Select All



CHARGING
CURVE SELECTION

- Disable
- Curve #1
- Curve #2
- Curve #3
- User's Definition

4. General Operation :

4.1 Connection

4.1.1 Automatic connection

Select a model and then click “ENTER” to proceed, shown as below. If connection is successfully established, “Open Connection” on the toolbar will light up. (The software will auto-detect the connection. If the programmer cannot be found please refer to connection error 5.1.)



4.1.2 Manual connection

During offline mode, complete the device configuration and then click “Open Connection” on the toolbar to proceed, shown as below. The software will auto-detect the corresponding COM port of the programmer.



4.1.3 Reconnection

To check if the device is connected effectively or replace a charger with the same model but different voltage type (e.g. ENC-120-12/24/48), please click “Check Model” on the toolbar, shown as below.



4.1.4 Disconnection

To disable the connection, please click “Close Connection” on the toolbar, shown as below.



4.2 Parameter programming/Reading

4.2.1 Download to device

In online mode, click “Download to Device” on the toolbar, show as below. (The function will be no response during offline mode, please establish connection first or refer to Connection 4.1)



There will be a notification once the programming is complete, click “Close” to close the window.

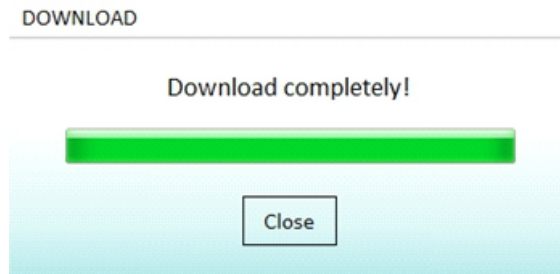

4.2.2 Upload to PC

In online mode, click “Upload to PC” on the toolbar, show as below. (The function will be no response during offline mode, please establish connection first or refer to Connection 4.1)



There will be a notification once the process is complete, click “Close” to close the window.

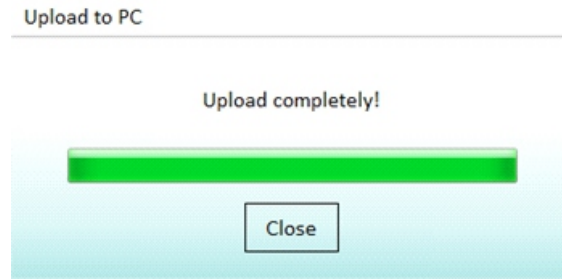

4.3 File saving/ loading

4.3.1 Loading a file

Click “Open” on the toolbar, shown as below.



There will be a File Open dialog window that appears

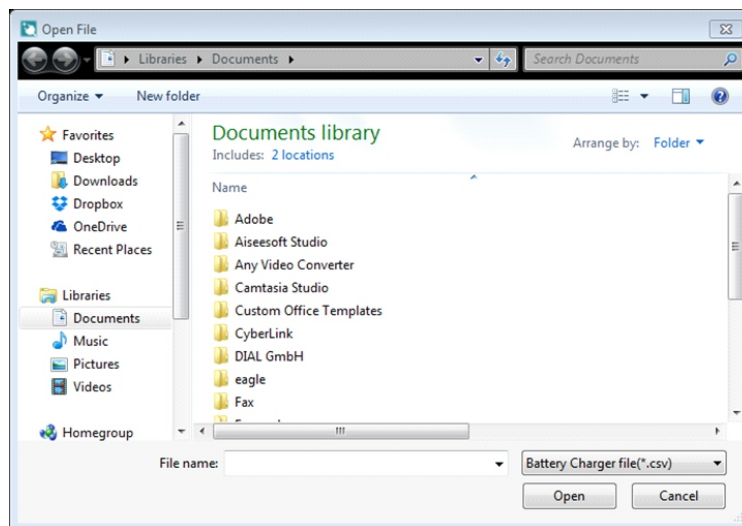

Select a file with SBP file extension of “.CSV” (This SBPSetting.csv is an example of explanation, shown as A marked in red in the picture below) and then click “Open” (as B) to load the file.

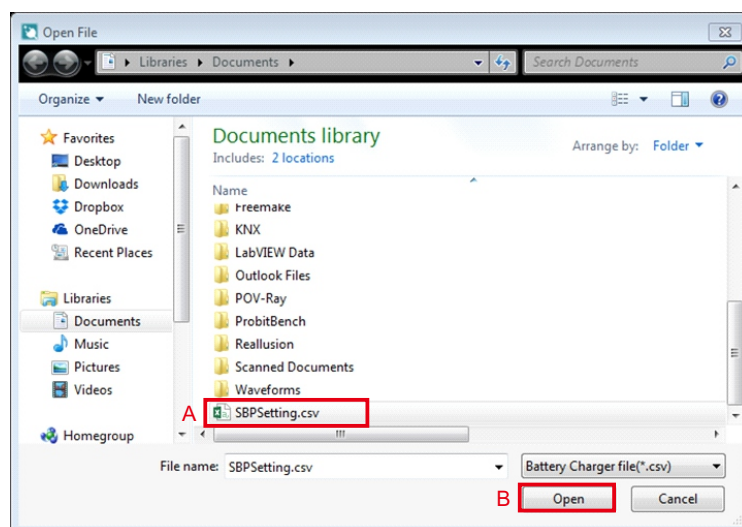

There will be a message notifying that the current setting will be lost, if continue. Click "YES" to proceed or "NO" to cancel it.

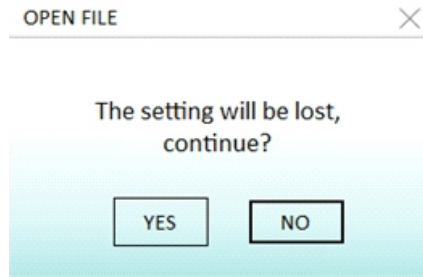

There will be a notification once the data is loaded, click "Close" to close the window.

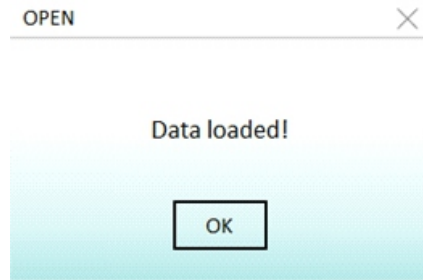

If selected file does match the current model, there will be a message of "The detected unit does not match to current setting from software. Continue?". Click "YES" to switch to the model and loading the data or click "NO" to cancel it.

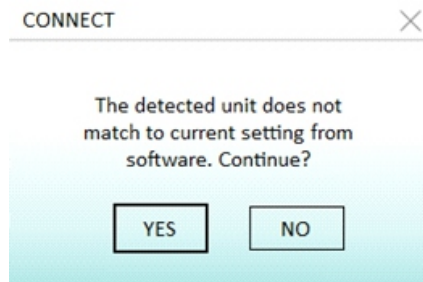

4.3.2 Saving a file

Click "Save" on the toolbar, shown as below.



There will be a file dialog window that appears

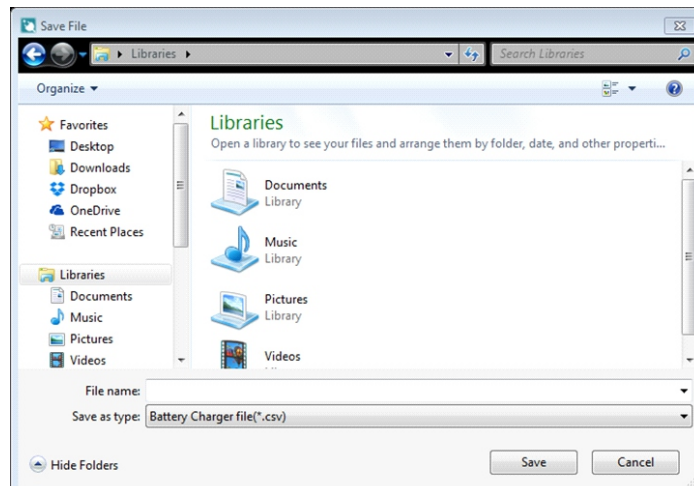

Type a file name (This SBPSetting.csv is an example of explanation, shown as A marked in red in the picture below) and then click “Save” (as B) to save the current settings.

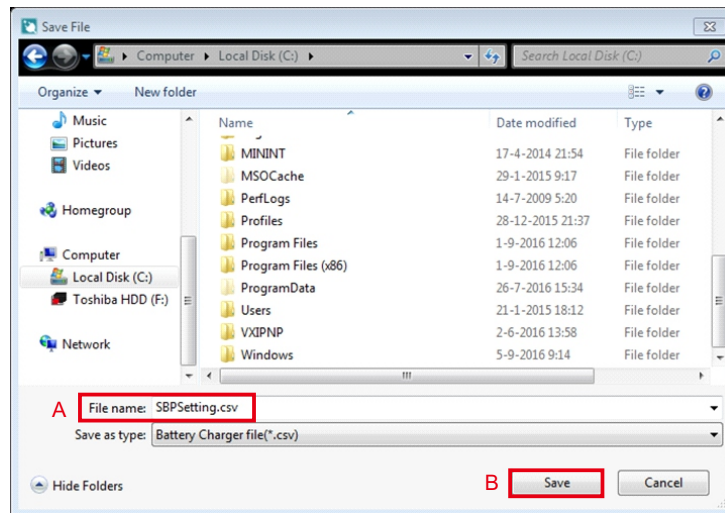

There will be a notification once the settings are saved, click “OK” to close the window.

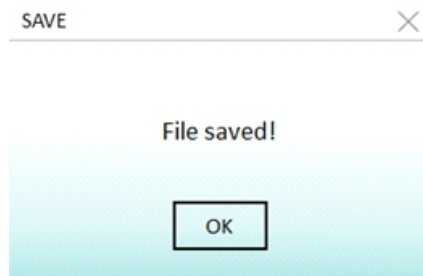

If this is the first time you are creating a save file, it will change to “Save As” automatically to proceed.

5. Troubleshooting :

5.1 Connection error

i. No charger detected

If there is a message of “No charger is detected. Keep offline mode”, meaning that the charger is either not connected or the connection is poor so that the software could not detect it. Please check the connection between the programmer and the charger before trying again.

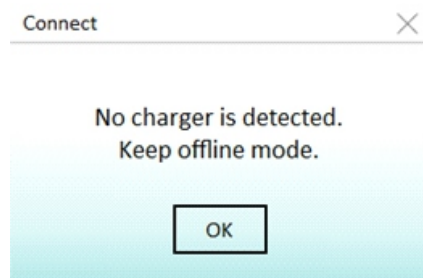

ii. No programmer detected

If there is a message of “No programmer is detected. Keep offline mode”, meaning that the programmer is either not connected or the connection is poor. Please remove the USB cable and reinsert it into the USB port again.

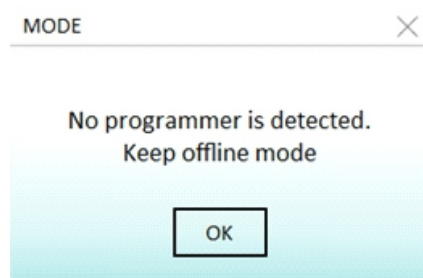

iii. Detected unit not matching the setting

If there is a message of "The detected unit does not match to current setting from software. Continue?", click "YES" to switch to the model or click "NO" to enter offline mode.

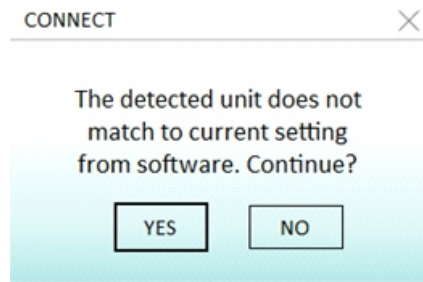

5.2 File loading/saving error

i. File loading error

The file has been opened: Please make sure there is no other software using the file before trying again.

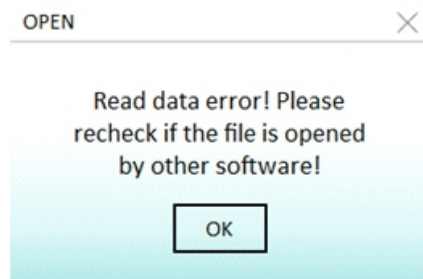

File format error: The selected file is not a SBP-001 file, please choose a correct file.



Model error: The selected file is not a supported model of SBP-001, please choose a correct file.



ii. File saving error

Model saving error: please select a voltage type.



The file has been opened: Please make sure there is no other software using the file before trying again.

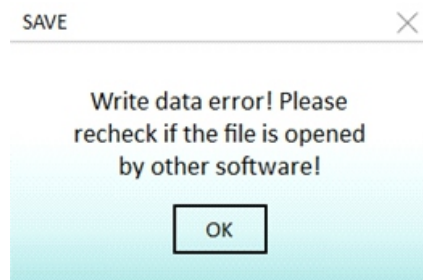

5.3 Uploading/downloading ERROR

i. Uploading error

No charger detected: Please check if there is a charger connected to the programmer, with a voltage type matching the current setting.

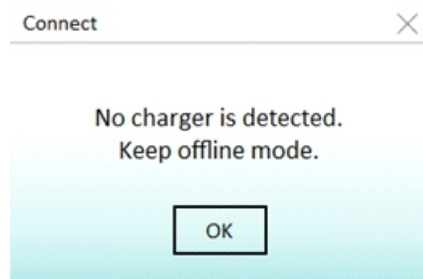

Programmer disconnected : Please check if the programmer is connected correctly.

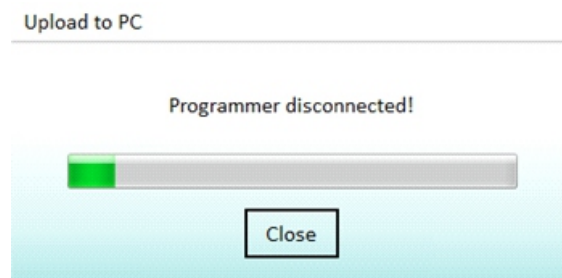

Upload error: Please check if all of the devices are connected correctly before trying again.

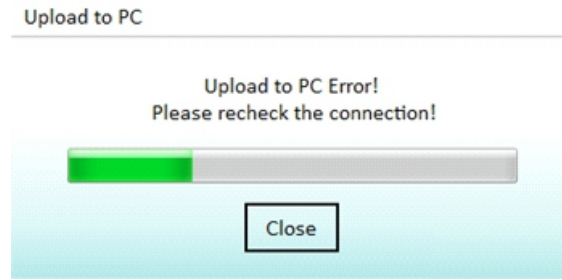

ii. Downloading error

No charger detected: Please check if there is a charger connected to the programmer, with a voltage type matching the current setting.

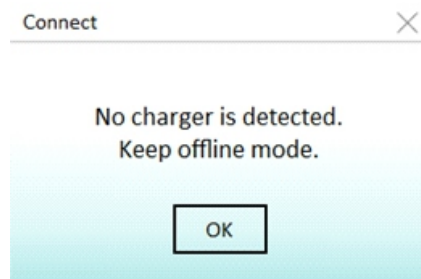

Programmer disconnected : Please check if the programmer is connected correctly.

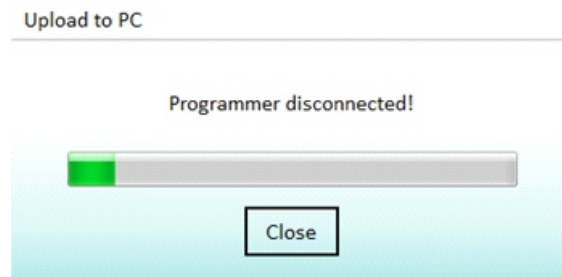

Download error: Please check if all of the devices are connected correctly before trying again.



6. Notes:

1. Please utilize a proper communication cable for programming. A non-authorized cable may cause a programming error.
2. The updated settings take effect after the charger is restarted. For ENC series, please disconnect the programmer before turning on the charger.
3. The following table lists which version of the software is required for each version of the chargers. For the best performance, you should use compatible version of software, SBP-001 and the chargers.

SBP-001 Software	SBP-001 Firmware	Product Firmware
R01.6	R01.3	HEP-1000(PMBus, CANBus) R01.0 and later DBR-3200(CANBus) R01.1 and later DBR-3200(PMBus) R01.0 and later DBU-3200(CANBus) R01.1 and later DBU-3200(PMBus) R01.0 and later RPB-1600(CANBus, PMBus) R02.0 and later RCB-1600(CANBus, PMBus) R02.0 and later ENC series R01.0 and later NPB-450/750(CANBus) R1.0 and later NPB-1200/1700(CANBus) R1.0 and later DRS-240/480(CANBus) R1.0 and later HEP-2300-55(PMBus, CANBus) R1.0 and later NCP-3200(PMBus, CANBus) R1.0 and later
R01.5	R01.3	HEP-1000(PMBus, CANBus) R01.0 and later DBR-3200(CANBus) R01.1 and later DBR-3200(PMBus) R01.0 and later DBU-3200(CANBus) R01.1 and later DBU-3200(PMBus) R01.0 and later RPB-1600(CANBus, PMBus) R02.0 and later RCB-1600(CANBus, PMBus) R02.0 and later ENC series R01.0 and later NPB-450/750(CANBus) R1.0 and later NPB-1200/1700(CANBus) R1.0 and later DRS-240/480(CANBus) R1.0 and later HEP-2300-55(PMBus, CANBus) R1.0 and later
R01.4	R01.3	HEP-1000(PMBus, CANBus) R01.0 and later DBR-3200(CANBus) R01.1 and later DBR-3200(PMBus) R01.0 and later DBU-3200(CANBus) R01.1 and later DBU-3200(PMBus) R01.0 and later RPB-1600(CANBus, PMBus) R02.0 and later RCB-1600(CANBus, PMBus) R02.0 and later ENC series R01.0 and later
R01.3	R01.2	DBR-3200(CANBus) R01.1 and later DBR-3200(PMBus) R01.0 and later DBU-3200(CANBus) R01.1 and later DBU-3200(PMBus) R01.0 and later RPB-1600(CANBus, PMBus) R02.0 and later RCB-1600(CANBus, PMBus) R02.0 and later ENC series R01.0 and later
R01.2	R01.1	RPB-1600(CANBus) R01.0~01.1 RPB-1600(PMBus) R01.0~01.7 RCB-1600(CANBus) R01.0~01.1 RCB-1600(PMBus) R01.0~01.6 ENC series R01.0 and later
R01.1	R01.1	RPB-1600(CANBus) R01.0~01.1 RPB-1600(PMBus) R01.0~01.7 RCB-1600(CANBus) R01.0~01.1 RCB-1600(PMBus) R01.0~01.6 ENC series R01.0 and later
R01.0	R01.0	ENC series R01.0 and later

明緯企業股份有限公司

MEAN WELL ENTERPRISES CO., LTD.

248 新北市五股區五權三路28號

No.28, Wuquan 3rd Rd., Wugu Dist., New Taipei City 248, Taiwan

Tel: 886-2-2299-6100 Fax: 886-2-2299-6200

<http://www.meanwell.com> E-mail: info@meanwell.com

Your Reliable Power Partner